

# Electrovision



**A195CA**  
**FIXED TV MOUNTING BRACKET**  
**Vesa Size : 600 x 400mm**  
**User Manual**  
**Notice d'Utilisation**

Thank you for purchasing an Electrovision bracket, please read these instructions carefully and leave with the user of the product for future reference.

# IMPORTANT

## **Installer and Users please note:**

These instructions should be read carefully and left with the user of the product for future reference.







## **BEFORE USE**

Inspect the product for any signs of damage. If the product is damaged, DO NOT use it, and contact your supplier immediately

## **PRODUCT SAFETY**

- Prior to the installation of this product, the installation instructions should be read and completely understood. The installation instructions must be read to prevent personal injury and property damage. Keep these installation instructions in an easily accessible location for future reference.
- **CAUTION:** The maximum load capacity is 40Kg. Use with products exceeding the maximum load capacity may cause serious injury. See appliance instructions.
- Do not install on a structure that is prone to vibration, movement or chance of impact. Failure to do so could result in damage to the display and/or damage to the stand.
- Do not place near heater, fireplace, air conditioning, in direct sunlight, or any other heat producing source. Failure to do so may result in damage to the display and could increase the risk of fire.
- It is recommended that two people perform the installation. Injury and/or damage can result from dropping or mishandling the display.
- The enclosed instructions are an aid to installation and cannot cover all eventualities, if you have any concerns regarding the mounting of the frame or brackets you should consult an expert.
- **CAUTION:** Before installation the mounting area should be checked that it is suitable for the weight of the bracket and screen and is free from pipes, electric cables or any other obstructions.

## TV MOUNTING ACCESSORIES

No	Part	Qty	No	Part	Qty
A 	M5 x 14mm	4	E 	Plug 10x60mm	4
B 	M6 x 14mm	4	F1 	Washer	8
C 	M8 x 14mm	4	G 	Spacer	4
D 	ST8 x 50mm	4			

## TOOLS REQUIRED

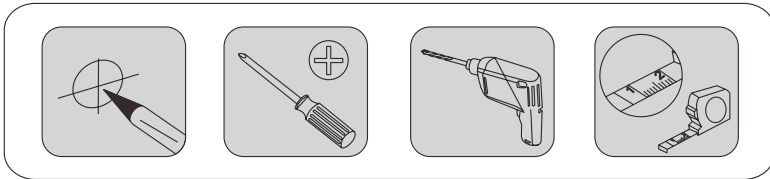

## STUD WALL FITTING INSTRUCTIONS

- Select a suitable position to mount the frame.
- It is recommended that the frame is mounted using the supplied bolts to the wooden supports behind the plasterboard. If you wish to mount directly to the plasterboard a survey of the plasterboard must be taken by suitably qualified installers and the correct mounting hardware must be purchased. The bolts and plugs provided are not suitable for this purpose.
- Use a stud detector to locate the centre points of 2 suitable wooden supports.
- Mark the 4 holes required using the built in spirit level (H) to keep the frame horizontal.
- Drill pilot holes 3mm diameter by 50mm deep in the supports.
- Attach the frame to the wall using the 8x50mm bolts (D), the bolts should be tightened using a 12mm / 1/2 inch socket wrench or spanner.

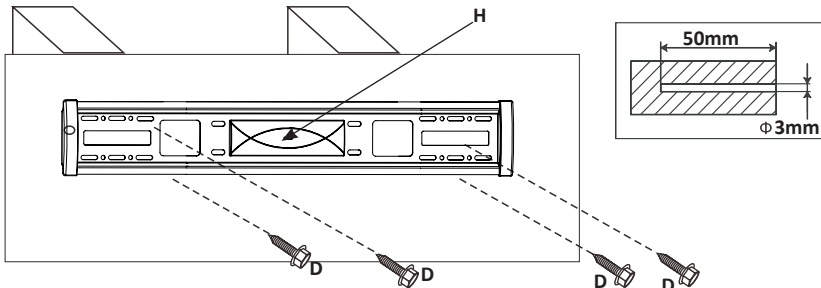

## BRICK/CONCRETE WALL FITTING INSTRUCTIONS

- Select a suitable position to mount the frame.
- Use a stud detector to check for hidden cables, pipes or steelwork.
- Place the frame against the wall and mark the 4 holes required, using the built in spirit level (H) to keep the frame horizontal.
- Drill the 4 holes with a 10mm diameter drill bit to a depth of 60mm.
- Insert the wall plugs(E).
- Attach the frame to the wall using the 8x50mm bolts (D), the bolts should be tightened using a 12mm / 1/2 inch socket wrench or spanner.

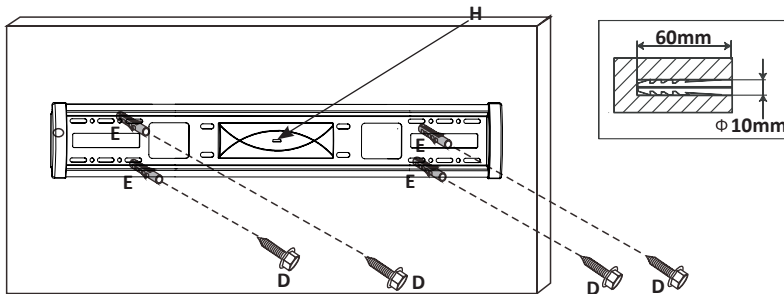

## ATTACHING BRACKETS TO TV

The A195C TV bracket comes with a range of TV mounting accessories designed to fit the majority of televisions. Depending upon the required parts it may be necessary to use screws A, B or C with the Washer (F1) and Spacer (G). The television should be laid flat on a soft surface so as not to damage or mark the screen.

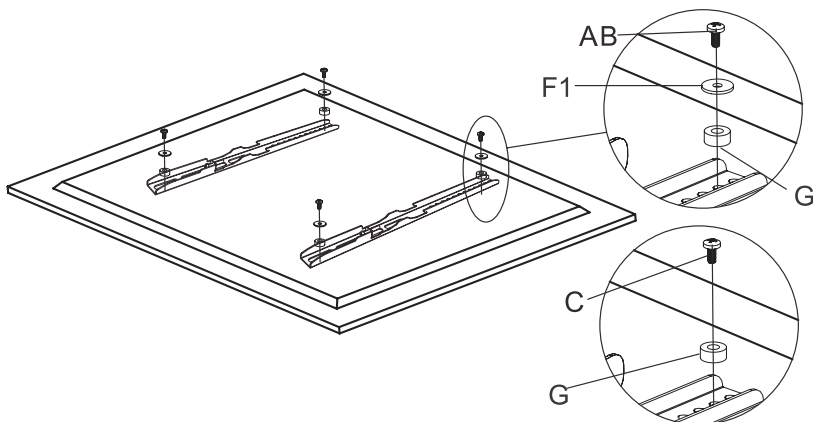

If the television has a curved back or includes an obstruction that may prevent the brackets from fitting flush to the back you can place the spacers (F1) beneath the brackets to lift away from the back. The brackets can now be secured with screws A, B or C with the Washer (F1) if necessary.

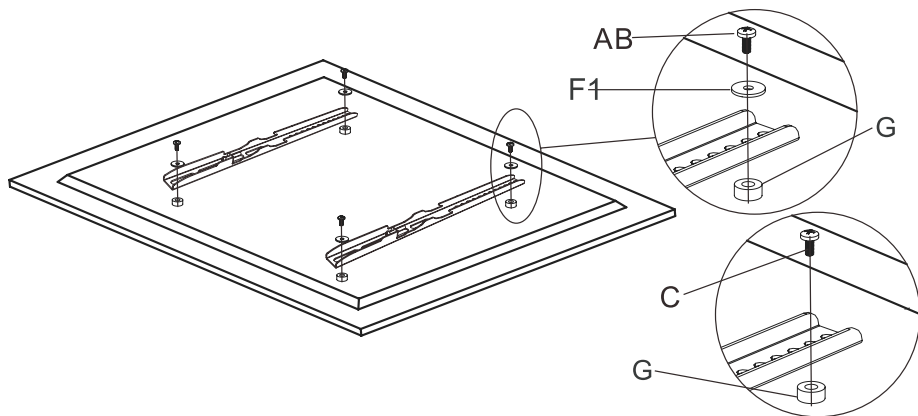

## ATTACHING BRACKETS & TV TO FRAME

Due to the risk of damage or injury it is recommended that a minimum of two people should be used to attach the television to the frame. The television should be tilted slightly backwards and the top hook section of the bracket should be placed on the top rail of the frame. The television should now be lowered onto the frame and the safety release cords should be pulled down to allow the bottom section of the bracket to click into place. Release the cords to secure the TV to the frame.

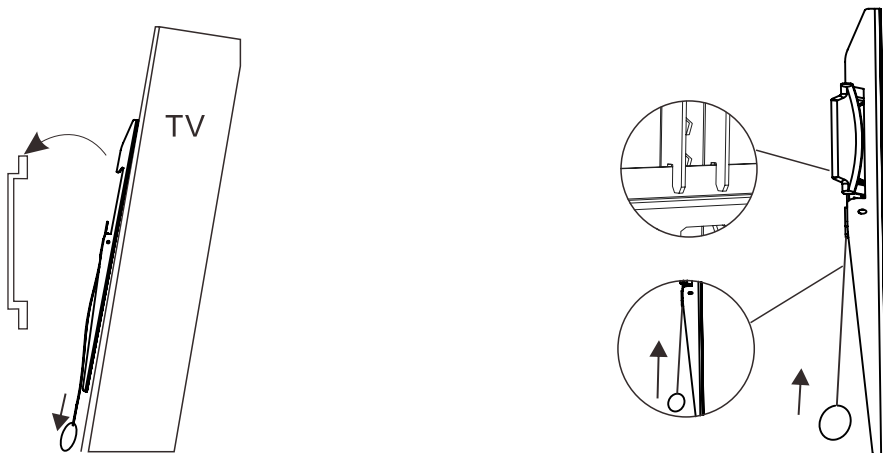

## **SERVICE WARRANTY**

Electrovision Ltd. guarantees the product free from defects in materials and workmanship for a period of twelve months.

Should this stand be operated under conditions other than those recommended, or any attempts are made to service or modify the stand, then the warranty will be rendered void. The product you buy may sometimes differ slightly from illustrations. This warranty is in addition to, and does not affect, your statutory rights.

Our guarantee is administered by our retailers.

If your product arrives damaged, you must contact the retailer from whom you bought it. The retailer's contact details will be on the invoice that arrived with the product, or on the e-mail you received when you placed the order. Do not contact Electrovision, only your retailer can arrange a replacement.

If the product needs to be repaired or replaced, you must contact the retailer from whom you bought it. The retailer's contact details will be on the invoice that arrived with the product, or on the e-mail you received when you placed the order.

If you have just received your product and require technical help in using it, please call our Help Desk on (0845) 459 4816

Electrovision Ltd.,  
Lancots Lane, Sutton,  
St. Helens, Merseyside.  
WA9 3EX  
[www.electrovision.co.uk](http://www.electrovision.co.uk)